

INSTALLATION INSTRUCTIONS FOR SELF-SUPPORTING DMX, DMXMD, DMXHD CONCRETE BASE TOWERS

<p>WARNING Survey your installation site NOW to prevent your antenna or support from coming in contact with overhead powerlines. FAILURE TO EXERCISE THIS CAUTION CAN CAUSE ELECTROCUTION</p>	<p>⚠ DANGER</p> 
---	--

CAUTION: SHARP EDGES—WEAR GLOVES

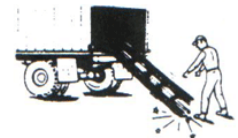

BREAKING DOWN BUNDLE

1. Remove the 8 ft. mast, the three 4 ft. base stubs and the package of nuts, bolts and washers.
2. Lay the bundle on its side and remove tower sections. Start with DMX-01 section (smallest section) and remove by pulling out with quick, firm jerks. It is not necessary nor desirable to pry sections out with tools.
3. Inspect all tower sections on delivery to make sure there are no loose or broken rivets caused by transport mishandling.

NOTE: Never install a tower or tower section found to have missing or damaged components. Only WADE replacement components or hardware may be used on DMX products. Failure to exercise this caution can result in injury or death. Consult distributors for replacement sections or parts if required.

SETTING THE BASE IN CONCRETE

1. Refer to page 3 for concrete recommendations.

NOTE: If the tower is being placed in loose soil, be sure to check with a local building contractor for advice on installing a deeper or larger base. This tower is no stronger than the base itself.

2. Fasten the 4 ft. base stubs to the outside of the tower base section. Insert a 1/2 inch bolt or rod about 1 inch long (not supplied) through each hole in the bottom of the base stubs to prevent the stubs from pulling out of the concrete.
3. Place the bottom tower section with base stubs attached into the hole and hold in a vertical position while concrete is poured in. Level the concrete even with the bottom of the base section.

NOTE: Since the three legs taper in about 1 degree, check each leg so they are all the same angle using a long level as shown at right.

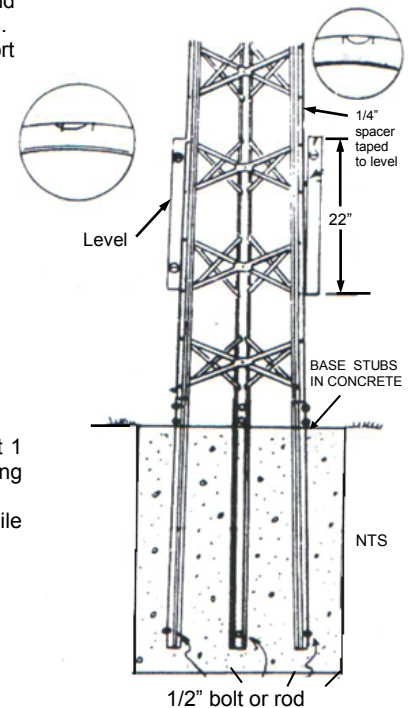

ERECTING TOWER

After the concrete is hard the tower is ready to be erected. We recommend the use of a “gin-pole” similar to the drawing on page two. The gin-pole is 15’ long and hooks into the “X” braces and straddles the tower leg. The rope which runs through the pulley is attached to the next tower section a bit above the centre of the section. A man on the ground can pull the section up and the man on the tower guides it into the top of the lower tower section. Special stop rivets prevent the upper section dropping too far inside. After the bolts and nuts are securely tightened the gin-pole can be unhooked and raised to the top of the next section and so on until the tower sections are all installed. The gin-pole is handy for installing the antenna and mast. The proper safety equipment and considerations as outlined in the servicing section of these instructions should be adhered to when climbing the tower for assembly or antenna adjustments. Gin-pole will fit from DMX-01 to DMX-06 sections.

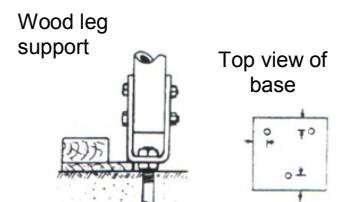

HUB HINGE-UP BASE FOR DMX TOWERS

1. Assemble the 3 legs of HUB and tighten all bolts and nuts securely. The threaded end of each long rod should not protrude more than 1/8” beyond nut or hinge — tube may catch on it when hinging.
2. Bolt HUB tubes on the INSIDE of each leg of bottom tower section. Make sure hinges all face the same direction.
3. Bent ends of legs are positioned away from each other.
4. Create base as outlined on page 3.
5. Place tower section, with HUB attached, into hole and hold it in a vertical position while concrete is poured in. Level concrete even with bottom of the lower nuts. Check all three legs with a level to make sure they all tilt the same (about 1 degree).
6. Wooden tower supports can be placed under the legs to hold them in position. Shims made from thin metal can be driven under legs until tower section is absolutely level on all three legs.
7. Make sure two legs are away from the building or the tower will not hinge up.
8. A block and tackle can be used to pull tower up.
9. Installing a safety anchor to prevent the tower from toppling is recommended.

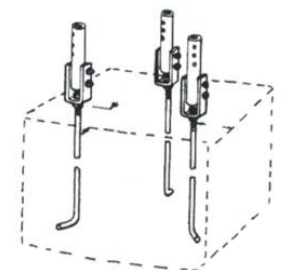

HUB Hinge-Up Base

TOWER HARDWARE

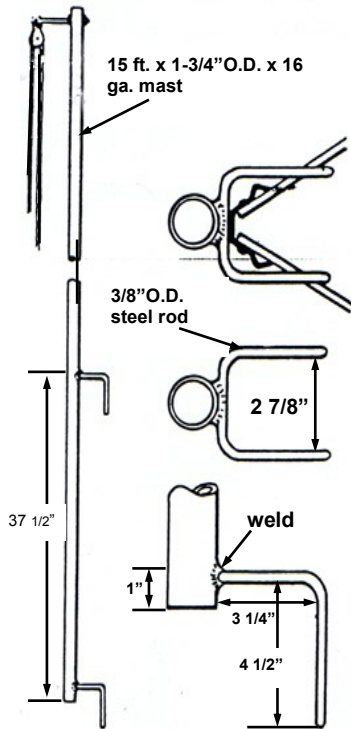

Gin-Pole Construction

WARNING

Do not replace hardware with common off the shelf product.
Please contact the factory for replacement hardware.

DANGER

IMPORTANT NOTE: The following procedure should be used when bolting tower sections together. Insert bolt through holes of the two sections. Place a lockwasher on the bolts and run the nut on. Only one lockwasher is required on each bolt and it is placed under the nut. These special heat treated bolts have solid shoulders in order to prevent the tower sections from shifting. Tighten the nut securely, but be careful not to strip the threads.

NOTE: 3/8" dia. X 5/8" bolts are used on DMX-01, DMX-02 and the top of DMX-03 sections. 1/2" dia. 3/4" bolts are used on the bottom of DMX-03 and on all sections (DMX-04 to DMX-08—DMX-08 is the largest section). Insert bolt from the inside of the leg, fastening washer and nut on the outside. All bolts and nuts are specially heat treated.

TORQUE SPECIFICATIONS:

3/8 inch dia.	25 ft.-lbs.
1/2 inch dia.	60 ft.-lbs.

Wade Towers are designed and built to stand up for years against severe wind and ice conditions. Although all towers are carefully made and inspected before they leave our factory, they are not guaranteed against failure due to shipping damage, over-loading or improper installation. Please read instructions carefully.

Do not overload towers with cross bar mounted antennas

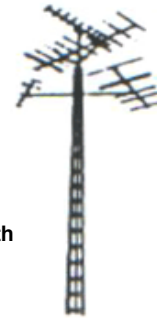

IMPORTANT

Fasten bolts from inside out

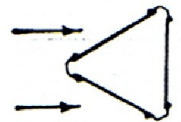
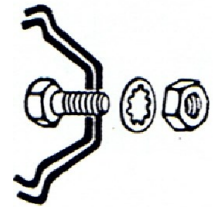

Install pointed toward most common prevailing winds

LOAD LIMITS

DMX Standard Duty Towers are designed to support up to 3 ft² (0.28m²) projected wind area.

DMXMD Medium Duty towers are designed to support up to 6 ft² (0.56m²) projected wind area.

DMXHD Heavy Duty towers are designed to support up to 9 ft² (0.84m²) projected wind area.

Note: Guy wires must be used for larger loads or if straight sections are added for additional height. However, the towers have not been tested to CSA standards CSA-S16-09 and CSA-S37-13 for loadings larger than what is indicated above.

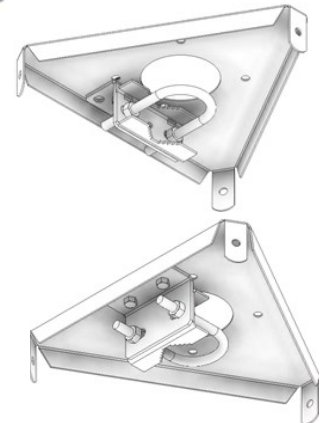

U-Bolt Assemblies with L-brackets

INSTALLING MAST

1. Two U-Bolt assemblies with L-brackets are supplied for installing the mast. These L-brackets are bolted, facing down, through the slotted holes on each plate with the short leg of the L-bracket toward the outside of the tower.
2. Adjustments to make the mast vertical may be made by moving the L-bracket in the slotted holes.
3. DM-Mast should be no more than 4 feet above the top of the tower.
4. A horizontal step is included in the top section to make it more comfortable for the installer when working on mast, rotator or antennas.

INSTALLING ROTORS

Any make of rotor can be installed on the rotor plate provided, inside the top section of a DMX tower for a neat appearance and also to make use of the mast thrust bearing on the top plate, which increases rotor life considerably.

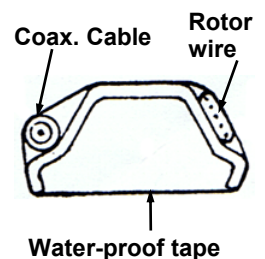

SERVICING

DMX Towers will withhold the impact load of a climber in case of a fall in accordance with CSA-S16-09 and CSA-S37-13, based on the conditions noted below:

- Tower must be properly maintained and in good condition with no structural defects or deterioration to its members capacities.
- The mounted appurtenances must adhere to the load limits as stated previously.
- During the time of servicing there must be no ice on the structure and wind speeds must not exceed 15km/h.
- The climber and all their equipment must not weigh more then 310lbs, and must be trained in basic fall protection and proper climbing techniques.
- The climber must be equipped with an E6 type lanyard in accordance with CSA-Z259, and it must be fastened to the tower leg on top of 2 cross braces using a double locking lanyard hook, as shown below.



CONCRETE BASE FOR DMX TOWERS

1. The DMX tower should be centered in a concrete base of dimensions 1676mm(66") deep by 1676mm(66") square.
2. The base must be reinforced with 10M rebar equally spaced at 305mm(12") O/C as shown below.
3. The rebar must be covered by 76mm(3") of concrete.
4. The base stubs must be submerged 1016mm(40") into the concrete.
5. The concrete must meet the following criteria: strength = 30mpa — 28 Days, 6% entrained air in base, compacted backfill to 95% PDD.

Note: Tower Foundation designed for DMX 68 tower to CAN/CSA-S37-01 for winds of 450Pa with 25mm(1") of ice. With assumed soil 190 KPA or 4000 PSF.

